

Submittal S30SZA2

30,000 BTU Wall Mount Heat Pump Ductless System

Job Name _____ Location _____ Engineer _____ Submitted To _____ Submitted By _____ Reference _____	Date _____ Approval _____ Construction _____ Unit No _____ Drawing No _____
---	--

FEATURES

- Heating down to -4°F (-20°C)
- Base Pan Heater
- Washable Filter
- Auto restart
- Quiet mode
- Min Heat 46°F
- °C & °F convertible
- 24 Hour Timer
- Horizontal Auto Swing Louver
- Compressor Pre-Heating

SYSTEM COMPONENTS

Indoor Unit Model Number	WHS30WMA21S
Outdoor Unit Model Number	WHS30SZA21S
System model number	S30SZA2

ELECTRICAL

Voltage/Phase/Frequency	208 / 230V, 1-Phase, 60Hz
Voltage Range - V	198 - 253
MCA - A	25
Max Circuit Breaker - A	35
Max. Current (Cooling) - A	15
Max. Current (Heating) - A	15
Rated Current (Cooling) - A	12.8
Rated Current (Heating) - A	12
Rated Input Power (Cooling) - W	2900
Min - Max Input Power (Cooling) - W	529 - 3450
Rated Input Power (Heating) - W	2700
Min - Max Input Power (Heating) - W	529 - 3450

CAPACITIES

Cooling Capacity - BTUh	30000
Cooling Capacity Range - BTUh	11500-33500
Heating Capacity - BTUh	31000
Heating Capacity Range - BTUh	11500-33500

FAN SPEEDS

Indoor Airflow Rate (S/H/M/L/Q) - CFM	1107/845/706/589/500
Indoor Airflow Rate (S/H/M/L/Q) - m³/h	1880/1435/1200/1000/850
Outdoor Airflow Rate (H) - CFM	2381
Outdoor Airflow Rate (H) - m³/h	4000

SOUND PRESSURE

Sound Pressure Level Indoor (S/H/M/L/Q) - dB(A)	50/45/43/40/38
Sound Pressure Level Outdoor (H) - dB(A)	60

LINESET REQUIREMENTS

Connection Pipe Diameter - Liquid (Flare) - in (mm)	3/8 (9.52)
Connection Pipe Diameter - Gas (Flare) - in (mm)	5/8 (15.88)
Minimum Lineset Length - ft (m)	10 (3)
Maximum Lineset Length (Total) - ft (m)	66 (20)
Max Height Difference (IDU higher than ODU) - ft (m)	33 (10)
Max Height Difference (ODU higher than IDU) - ft (m)	16 (5)
Pre-charged Lineset Length - ft (m)	25 (7.5)

ETL: 3088177
OUTDOOR TEMPERATURE OPERATING RANGE

Cooling - °F (°C)	5°F to 115°F (-15°C to 46°C)
Heating - °F (°C)	-4°F to 75°F (-20°C to 24°C)

INDOOR TEMPERATURE SETTING RANGE

Cooling - °F (°C)	61°F to 86°F (16°C to 30°C)
Heating - °F (°C)	61°F to 86°F (16°C to 30°C)

Moisture Removal pints/h (L/h)	6.34 (3)
--------------------------------	----------

EFFICIENCIES

SEER	18.8	SEER2	18.5
EER	10.3	EER2	10
HSPF	12.3	HSPF2	9
COP - BTU	11.5	COP2 - BTU	10.39
COP. - W/W	3.37	COP2. - W/W	3.05
Energy Star			No

NET DIMENSIONS & WEIGHTS

Indoor Unit Net Dimensions (W x H x D) - in	50 6/16 x 14 3/16 x 10 4/16
Indoor Unit Net Dimensions (W x H x D) - mm	1280 x 360 x 260
Indoor Unit Gross Dimensions (W x H x D) - in	54 8/16 x 17 2/16 x 12 13/16
Indoor Unit Gross Dimensions (W x H x D) - mm	1385 x 435 x 325
Outdoor Unit Net Dimensions (W x H x D) - in	34 13/16 x 31 5/16 x 14 7/16
Outdoor Unit Net Dimensions (W x H x D) - mm	885 x 795 x 366
Outdoor Unit Gross Dimensions (W x H x D) - in	41 5/16 x 35 1/16 x 19 11/16
Outdoor Unit Gross Dimensions (W x H x D) - mm	1050x890x500
Indoor Unit - Net Weight - lbs (kg)	40 (18)
Outdoor Unit - Net Weight - lbs (kg)	128 (58)

REFRIGERANT

Refrigerant Type	410A
Refrigerant Weight - lb oz	4 lb 9 oz
Oil type	HAF68D1C

COMPRESSOR

Compressor Type	Rotary
-----------------	--------

WARRANTY

7 Year Compressor, 5 Year Parts Warranty
Note: Specifications are based on the following conditions:
Cooling: Indoor temperature of 80°F (26.7°C) DB/67°F (19.4°C) WB, and outdoor temperature of 95°F (35°C) DB/75°F (23.9°C) WB.
 Heating: Indoor temperature of 70°F (21.1°C) DB/60°F (15.6°C) WB, and outdoor temperature of 47°F (8.3°C) DB/43°F (6.1°C) WB.
 Pipe length: 25ft. (7.5m), Height difference: 0ft. (0m) (Outdoor unit – indoor unit).

Submittal S30SZA2

30,000 BTU Wall Mount
Heat Pump Ductless System

DIMENSIONS

Unit: In. (mm)

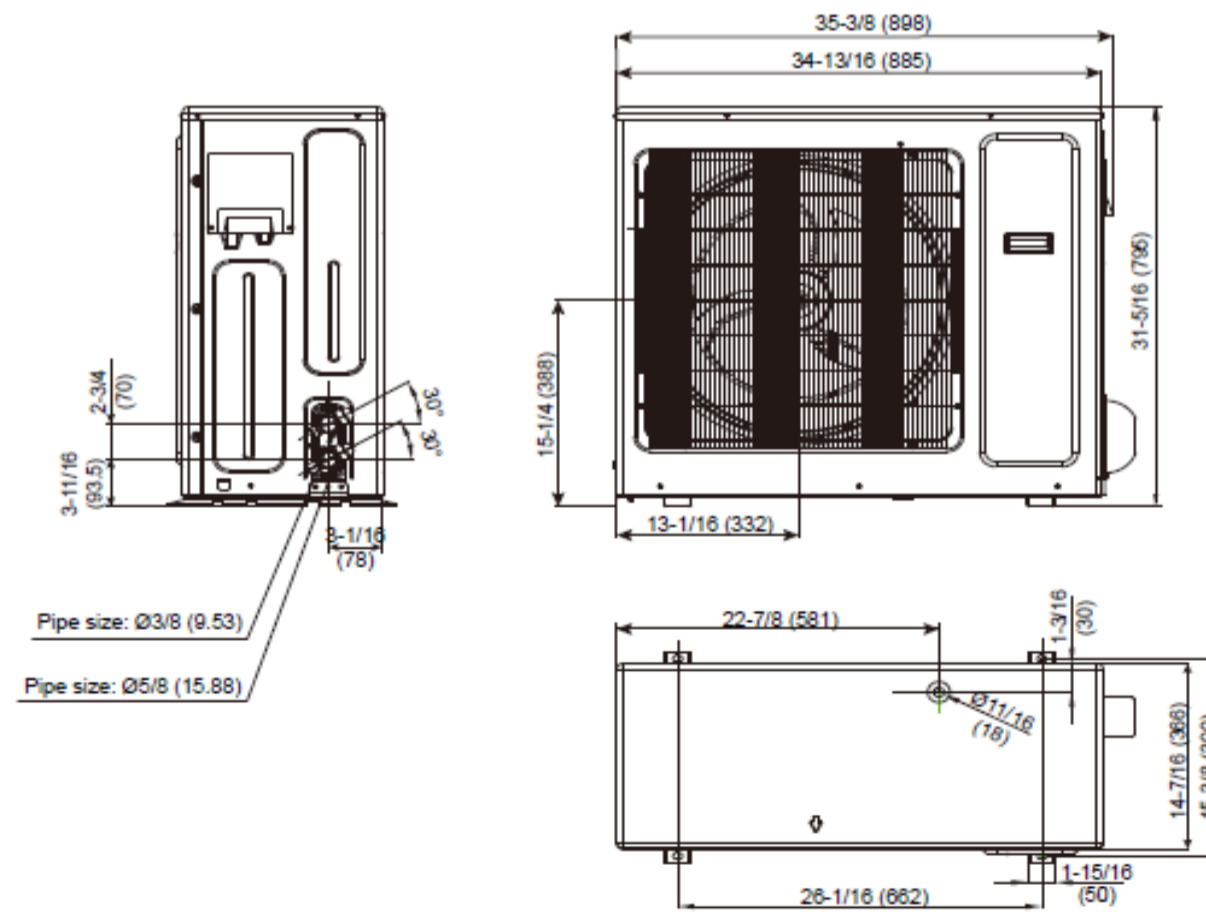
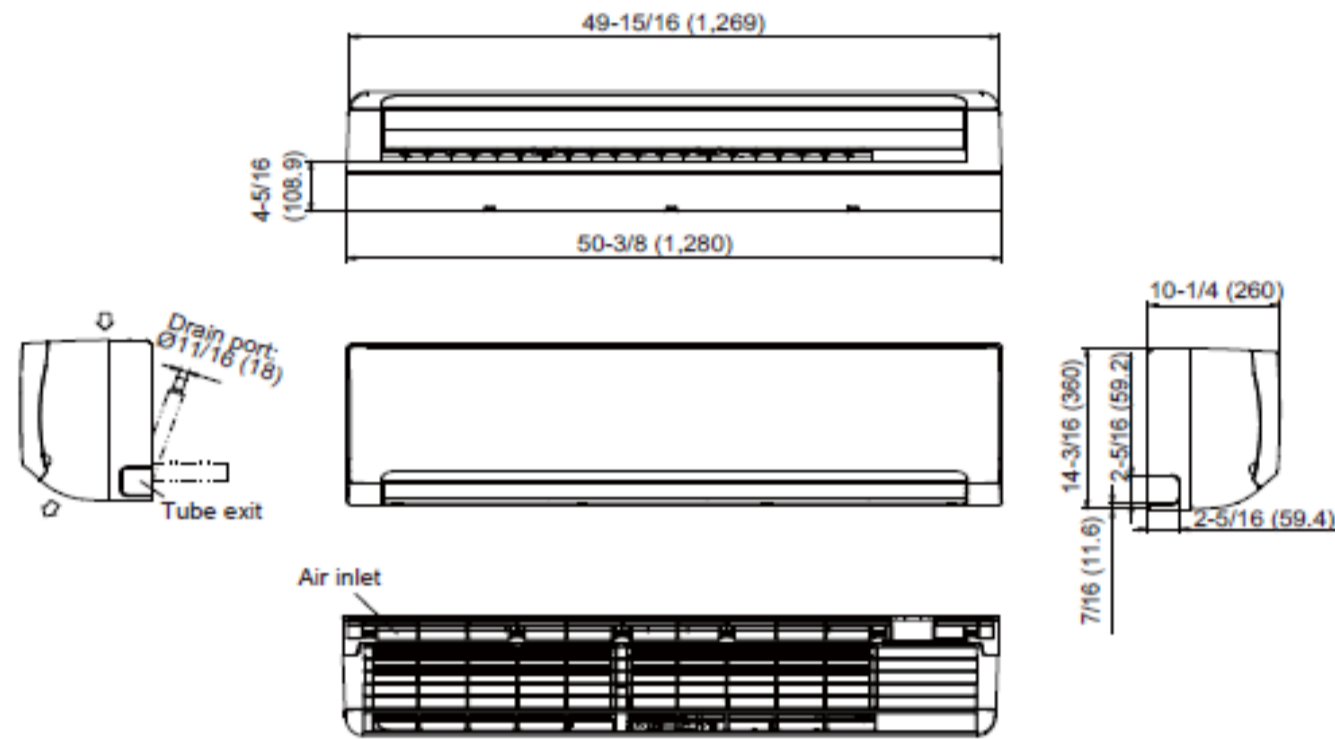

 and WESTINGHOUSE are trademarks of Westinghouse Electric Corporation. All Rights Reserved.